

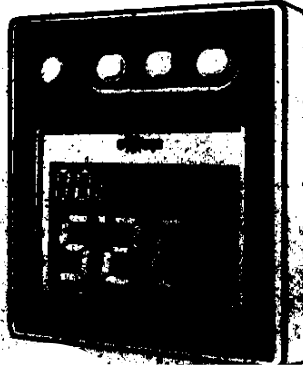

# CENTRAL

FOR  
INSTRUCTION & INSTALLATION MANUAL

# *Dateline*



Stowe Marine Limited, 235 Bentley Way, LYMINGTON SO41 8JW

[www.stowemarine.com](http://www.stowemarine.com)

[infor@stowemarine.com](mailto:infor@stowemarine.com)

# *Dataline*

INSTRUCTION & INSTALLATION MANUAL  
FOR

## **CENTRAL**

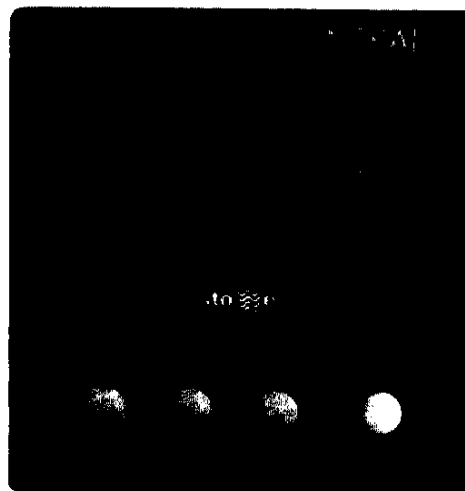

**CONTENTS**

	<b>Page</b>
1. INTRODUCTION TO DATALINE .....	3
2. DATALINE SYSTEM DIAGRAM .....	5
3. DATALINE CENTRAL TECHNICAL SPECIFICATION .....	6
4. INSTRUMENT HEAD INSTALLATION .....	7
5. DATALINE CENTRAL OPERATING INSTRUCTIONS .....	9
Moving Cursor .....	12
Pages 1 — 6 .....	13—18
Resetting .....	19
Enable/Disable Depth Alarms .....	20
Setting Depth Alarm Values .....	21
Setting Lighting Levels .....	23
Calibration .....	24
6. OPERATIONAL CHECKLIST & TROUBLE SHOOTING GUIDE .....	31
7. CARE AND MAINTENANCE OF INSTRUMENT HEAD .....	33
8. REMOVAL OF THE INSTRUMENT .....	33
9. SERVICE .....	34
10. WARRANTY .....	34
11. STOWE — U.K. SERVICE DEALERS .....	35
12. OVERSEAS DISTRIBUTORS .....	36

**1. INTRODUCTION TO DATALINE**

DATALINE is a major advance in marine instrumentation.

Conceived by Stowe, a world leader in the manufacture of marine instruments, DATALINE fully utilises all the skill and experience acquired over 8 years manufacturing products such as the internationally acclaimed Navigator and Micro ranges of sail and powerboat instruments.

DATALINE takes all the recognised Stowe hallmarks of quality, ruggedness and reliability and combines them with the technological and visual appeal needed to satisfy the many and varied demands of today's yacht and powerboat owners.

Most significantly, though, DATALINE achieves this in a way that brings unprecedented benefits not only to the end user, but also to the boatbuilder and electronic installation specialist.

**This is how it works:**

The DATALINE system, as the name implies, is based on a single cable which carries both the power and the data round the boat on a serial Databus using a communication language called NMEA 0183.

This language is the established industry standard and since DATALINE provides both NMEA 0183 inputs and outputs, compatibility is achieved with other navigational aids, such as Satnavs, compasses, plotters and autopilots, which use the same language. By adopting the industry standard the boat's information system is not subject to the 'closed system' constraints of some manufacturers' products so you are free to interface with other compatible navigational aids, irrespective of manufacturer.

The signal is generated from the DATABOX which is installed in a safe, dry environment below deck near the mast, or behind the chart table, or perhaps in the engine compartment of a powerboat. All sensors are wired to the DATABOX.

The DATALINE itself is then THE ONLY WIRE that runs to the instruments, which are simply linked together in a 'daisy chain' in whatever order suits the installation.

The DATALINE system has the capability of linking from one up to 15 instruments and remains as flexible and as viable for any installation, big or small, power or sail.

Since the DATABOX contains the total capability of the system any additional instrument head can be simply connected into the line without any upgrade to the electronics.

A complete range of analogue and digital instrument heads provides unparalleled flexibility for use in cockpit, flybridge, chart table, or indeed any location on the boat.

In addition to the advances and benefits inherent in the DATALINE system concept, the instrument heads themselves incorporate design features that place DATALINE many years ahead of any comparable instrument system. These include an integral moulded window for water tightness and damage resistance, removable dessicant pack and replaceable clip on cover.

**2. DATALINE SYSTEM DIAGRAM**

The DATALINE range of yacht instruments includes SPEED multifunction, DEPTH, WIND, WIND PLUS, WAYPOINT Decca/Loran repeater, S/D speed/depth dual display and CENTRAL multifunction instrument.

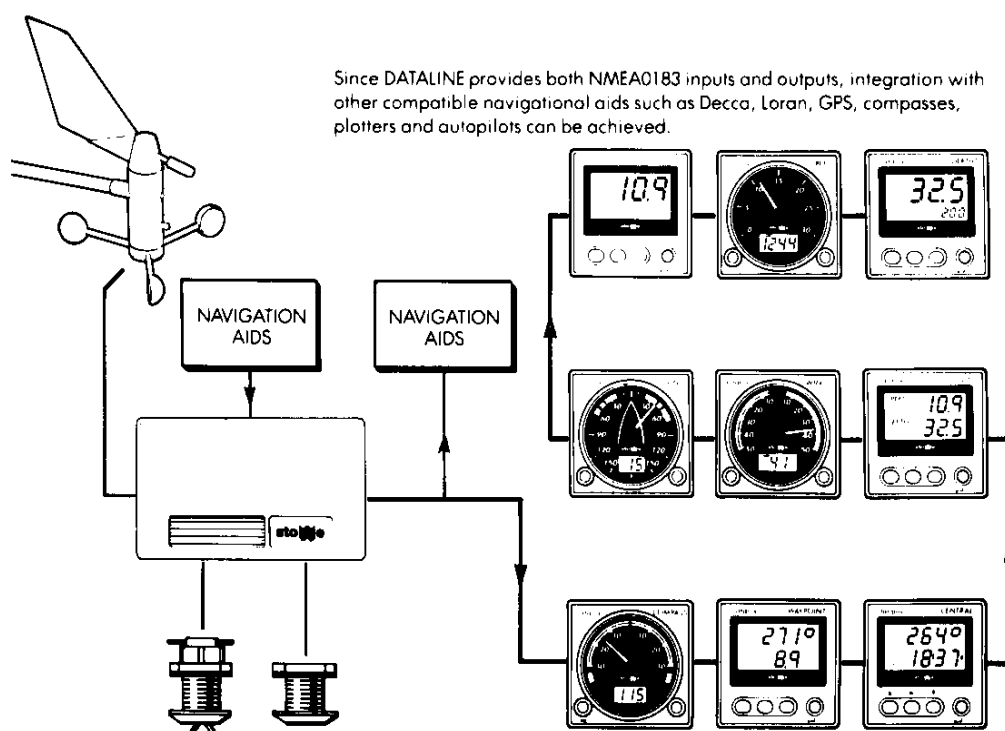

### 3. DATALINE CENTRAL

#### Technical Specification

Electronics	8 Bit Micro + 8K of ROM	
Power	10 -- 16V @ 10mA plus 60mA for lighting when required	
Temperature Range	- 10°C to 70°C	
Size	110 × 110 × 17mm	Depth Overall 38mm
	4½ × 4½ × ¾ inches	Depth Overall 1½ inches
Weight	210 grams	
Mounting Hole Size	50mm (2 inches)	
Speed Range	0 to 99.9 knots, resolution 0.01 knot, accuracy ±3%	
Depth Range	0.8 to 120m, resolution 0.1m, accuracy ±5%	
	2.8 to 394ft, resolution 0.1ft, accuracy ±5%	
Windspeed Range	0 to 99.9 knots, resolution 0.1 knot, accuracy ±3%	
Windangle	Resolution 1 degree, accuracy ±2%	
Heading	Resolution 1 degree	
Sea Temperature Range	- 10°C to 40°C, resolution 1°C, accuracy ±2%	

### 4. INSTRUMENT HEAD INSTALLATION

The instrument head is fully waterproof and can therefore be installed on deck or below. The connections should be protected from water penetration and should, if possible, allow rear access to remove the dessicant pack annually. The position selected should in the first instance meet the requirements of the helmsman or crew. The analogue head should be at least 150mm (6") away from a magnetic compass.

The selected surface must be flat and even to within 0.5mm.

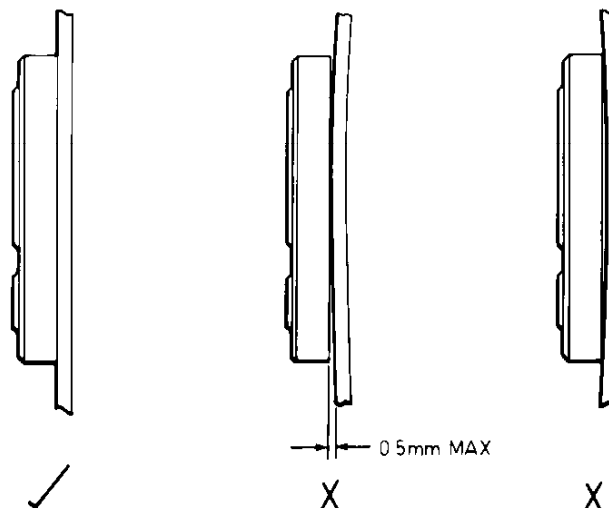

**N.B. DO NOT OVERTIGHTEN FIXING SCREWS**

- Step 1** Once a suitable position has been found, the installation can begin. For security reasons a note should be made of the unit serial number, and kept in a safe place.
- Step 2** Carefully position the self-adhesive template provided on the surface where the instrument is to be mounted.
- Step 3** Drill a small pilot hole first and then check the location on the other side of the panel or bulkhead to confirm suitability.
- Step 4** Open hole out using a 50mm (2") cutter in a hand held brace or electric drill. Drill the 4 fixing holes using a 2.5mm (3/32") drill.
- Step 5** Connect the instrument to the Dataline wire, making sure that the colours are correctly wired to the terminals. The Dataline wire can either be taken from the Databox or from any convenient instrument head. Instrument heads can be connected in any order.

### Connection Diagram



- Step 6** Before finally fixing the instrument in position, the installation should be checked functionally.
- Step 7** If it is not possible to gain access to the instrument back when fitted, the terminals at this stage should be covered with a liberal coating of silicone grease, vaseline, WD40 (or similar moisture dispersant). These materials will not harm any other instrument components.
- Step 8** Secure the instrument head in place using the 4 No. 6 self tapping screws provided and ensure the sealing gasket is correctly located. DO NOT OVERTIGHTEN as the instrument can be permanently damaged if distorted tighten screws lightly and evenly.
- WARNING:** DO NOT use any form of sealing compound on the instrument back. This can damage the instrument and prevent access to the dessicant pack.
- Step 9** Finally, the cover of your choice, black or white, can be clipped on over the instrument.

### Quick Reference Chart

△ ▽	▷	▷	▷
PAGE 1	BOAT SPEED DEPTH (METRES)	AVERAGE SPEED DEPTH (FEET)	
PAGE 2	AWS AWA	BOAT SPEED (TWS), (TWA)	
PAGE 3	AWS VMG	TWS RACE TIMER	BOAT SPEED
PAGE 4	MAG. HEADING PASSAGE TIMER		
PAGE 5	SEA TEMP. (°C) BATTERY VOLTAGE	SEA TEMP. (°F) ENGINE HOURS	
PAGE 6	LOG 1 LOG 2		

**Calibration Page**

▷					
CAL LOG	CAL MHU OFFSET	CAL DEPTH OFFSET	CAL SHAL ALARM	RESET LOG 1	RESET ENGINE HRS

**Alarm Page**

▷	
SHALLOW ALARM	DEEP ALARM

**5. DATALINE CENTRAL OPERATING INSTRUCTIONS**

**Notes on using this guide**

This guide has been written to allow the user to get the most out of the instrument. The diagrams included show the button sequences and the displays expected. NOTE: The values used in the diagrams are imaginary and should not be expected in any set-up.

**Notes on setting alarms/calibration**

When setting an alarm level or calibration factor, the value will automatically control all other instruments in the system, i.e. only one head needs to be set.

**Using buttons**

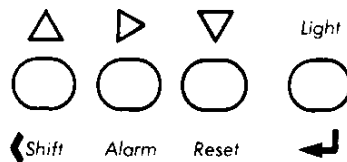

The grey symbols and text above the buttons are the main function of that button; the text below the button is only selected when used in conjunction with the orange LIGHT button. To be sure that a function has been selected, the unit will 'beep' when a button is pressed.

**Special Notes on using the Central Instrument**

The Central is unique in the Dataline range in such that it is not set up in the same way as the other instruments. It uses 6 pages of information which may be selected by the user. Each page comprises 2 or more items of information. The UP ( △ ) arrow is used to go forward a page. The DOWN ( ▽ ) arrow is used to go back a page. To access the extra information off the screen the ACROSS ( ▷ ) arrow is used.

**FUNCTIONS**

On powering up the system, the LCD will show all segments for approximately one second.

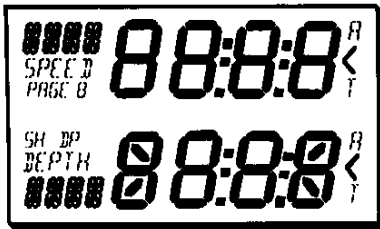

The display will then show the current operating values on Page 1.

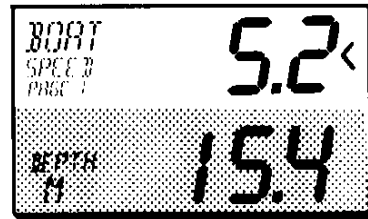

The function guide following shows what information is on which page. Each page has been taken in order. The button pressing sequences for changing pages has been removed to aid clarity.

**MOVING THE CURSOR**

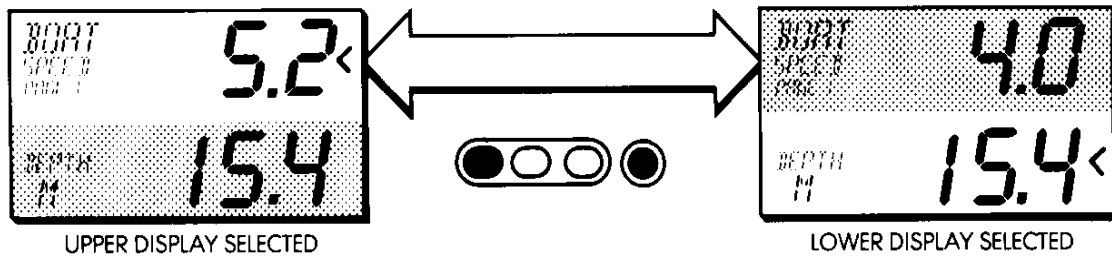

**FUNCTIONS OF PAGE ONE**

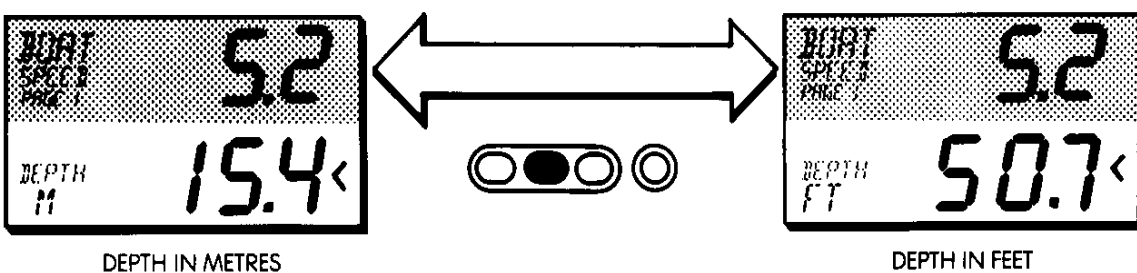
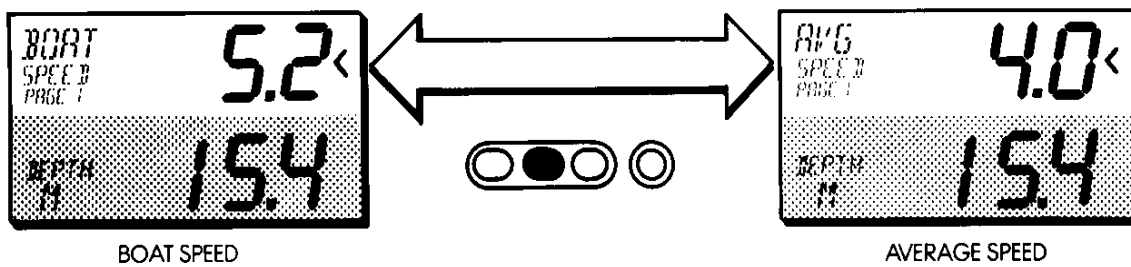



FUNCTIONS OF PAGE TWO

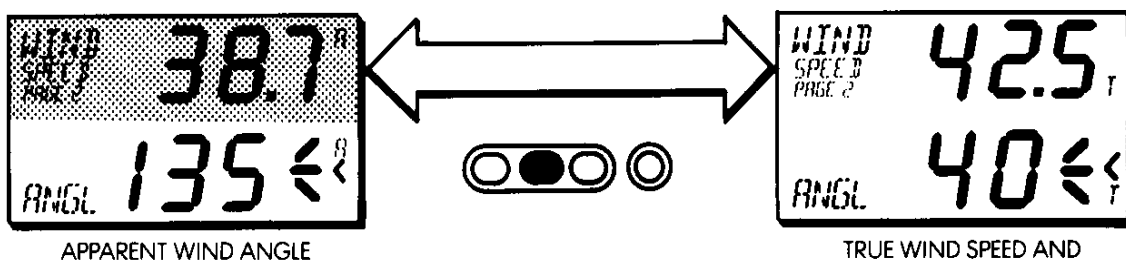
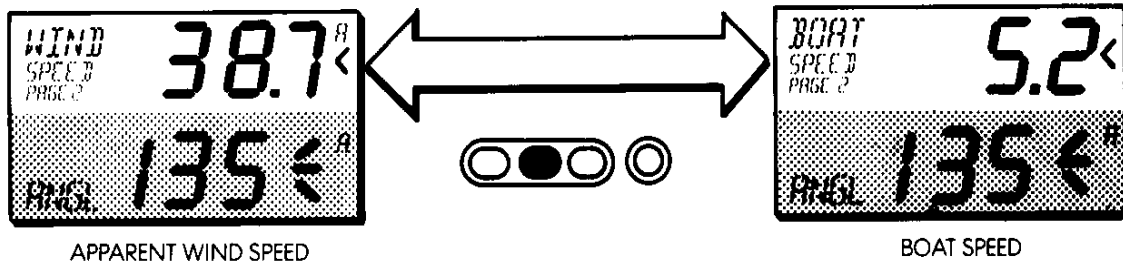

FUNCTIONS OF PAGE THREE

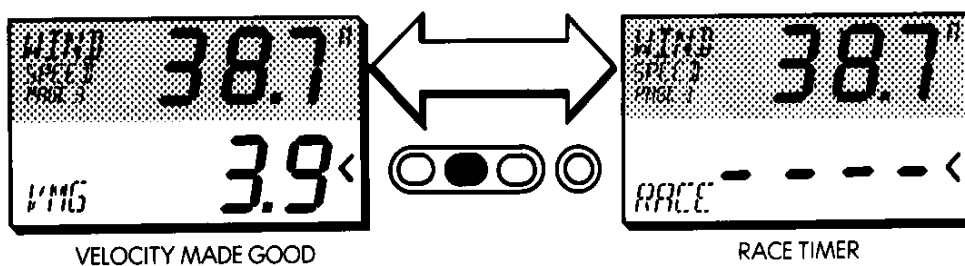
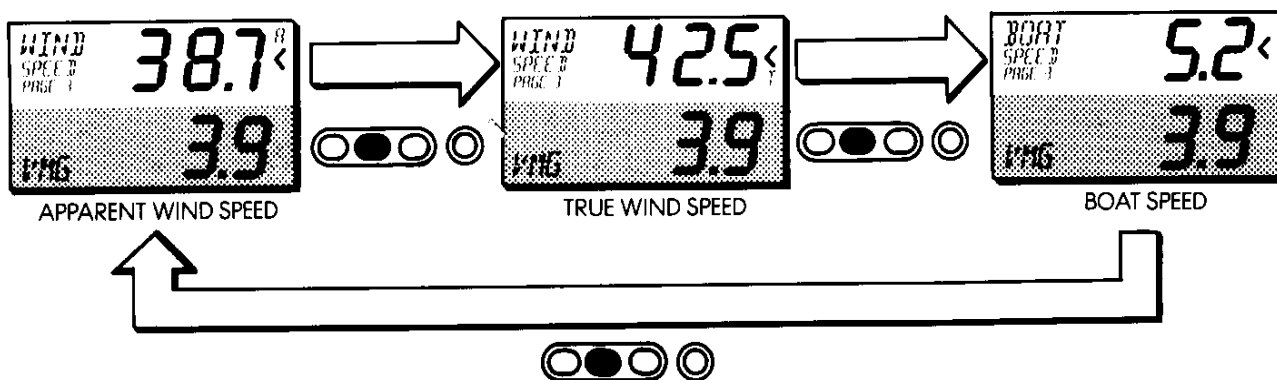

**FUNCTIONS OF PAGE FOUR**

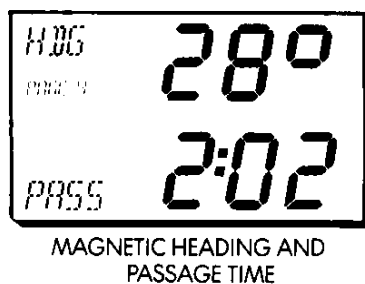

PLEASE NOTE THAT THE COMPASS HEADING SENSOR CANNOT BE CALIBRATED FROM THE CENTRAL UNIT.

**FUNCTIONS OF PAGE FIVE**

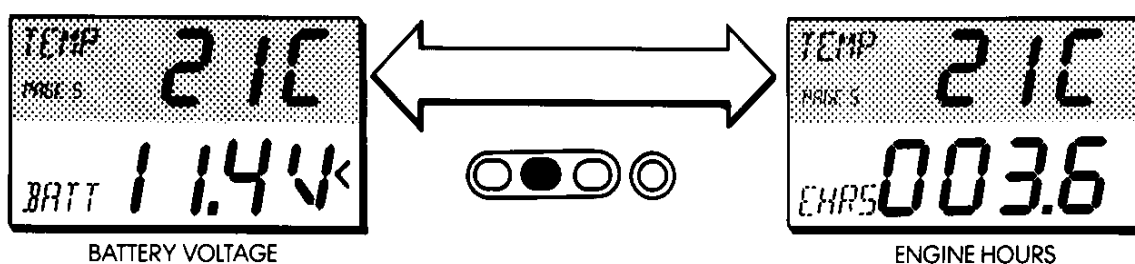
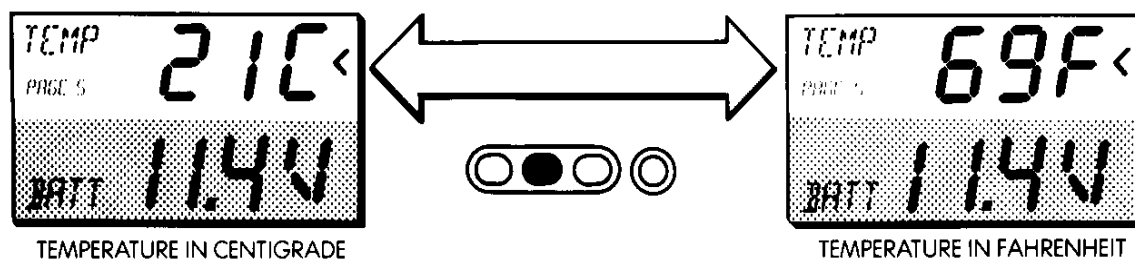

**FUNCTIONS OF PAGE SIX**

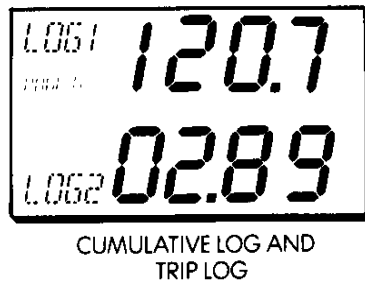

**RESETTING**

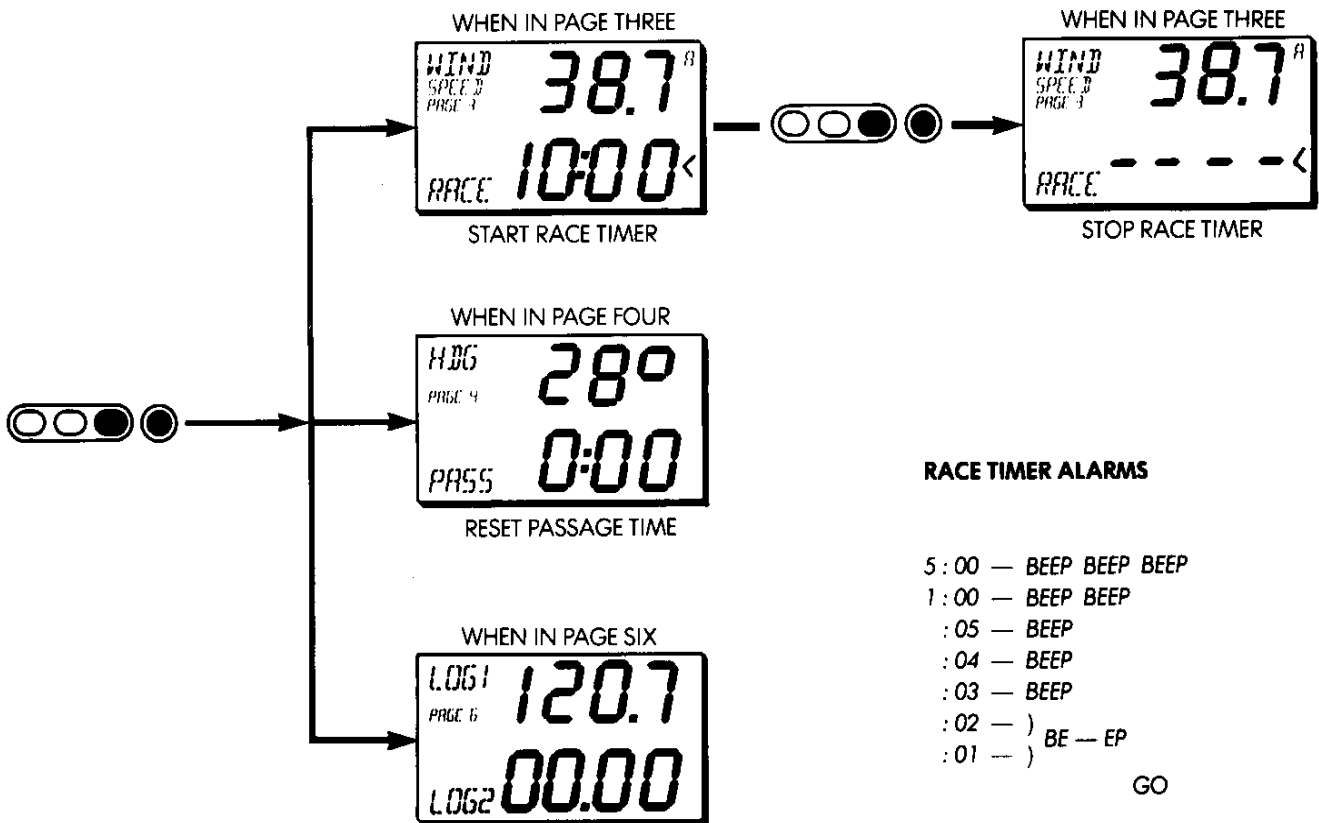

### ENABLE/DISABLE DEPTH ALARMS

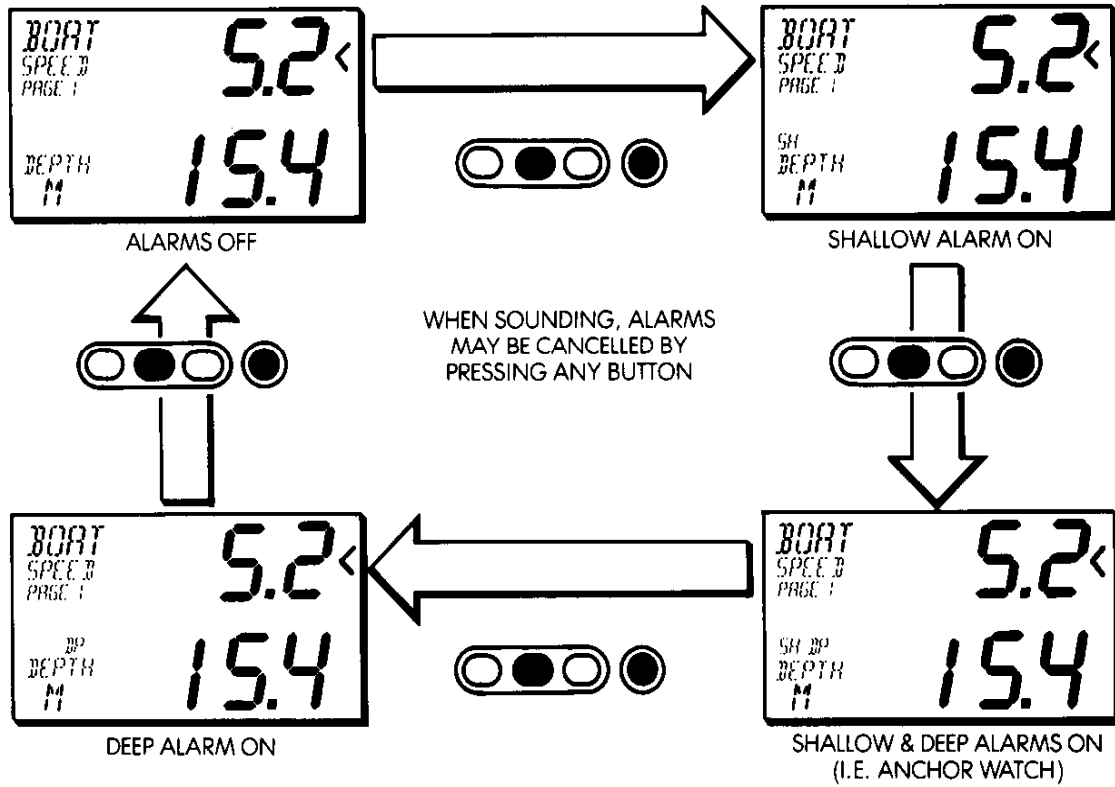

### SET DEPTH ALARM VALUES

DEPTH UNITS MAY BE CHANGED IN THIS MODE ONLY, BY PRESSING THE UP BUTTON AND THE LIGHT BUTTON TOGETHER.

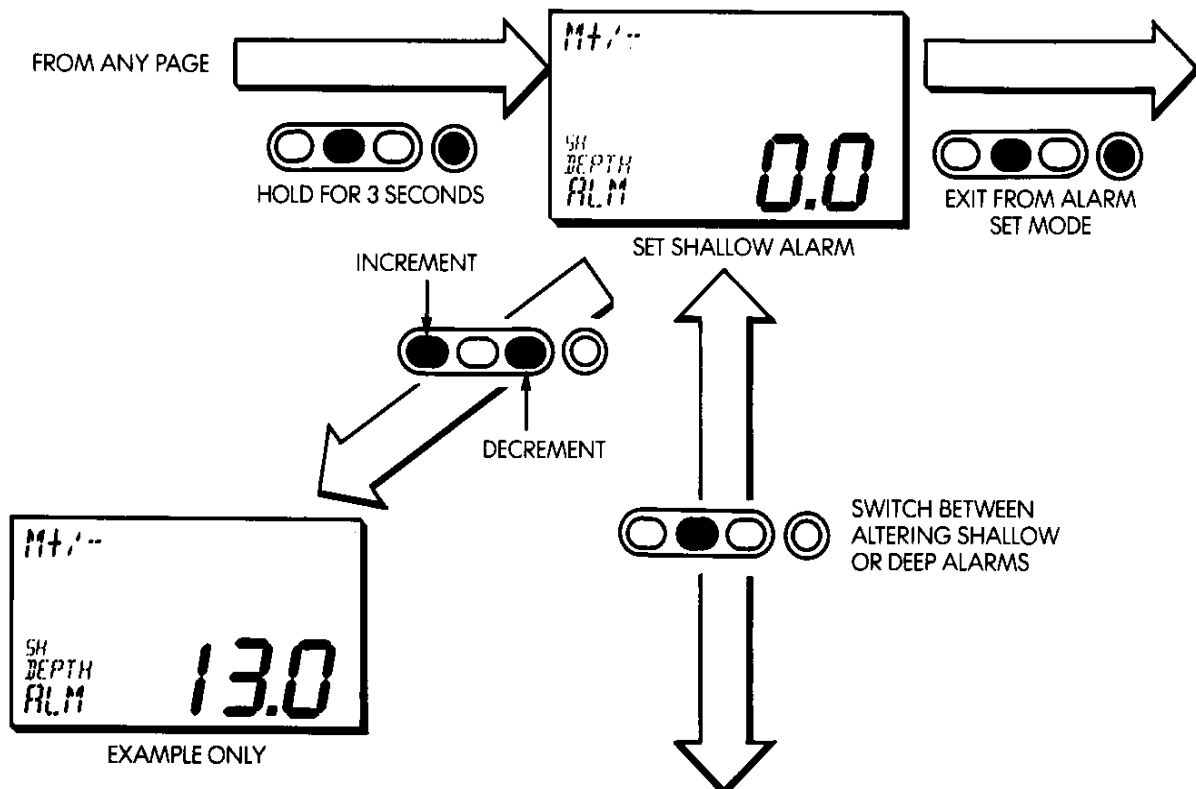

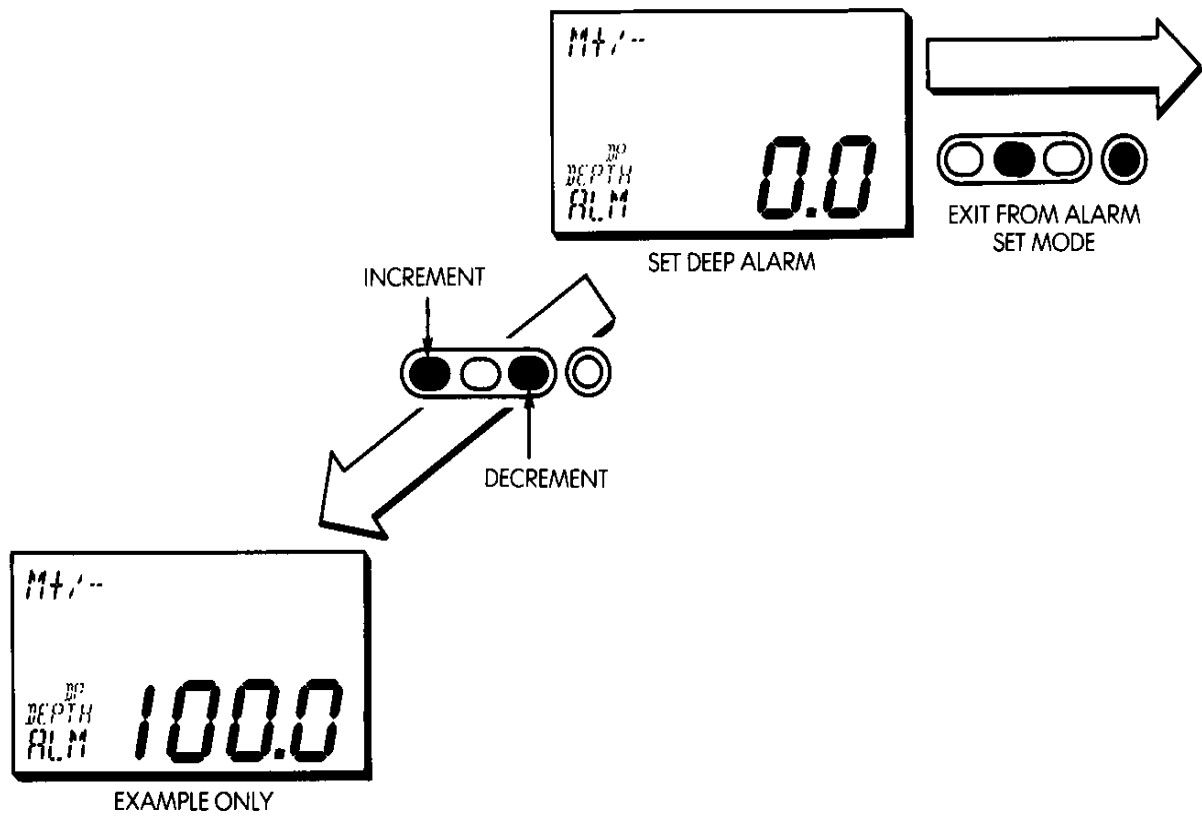

### SET LIGHTING LEVEL

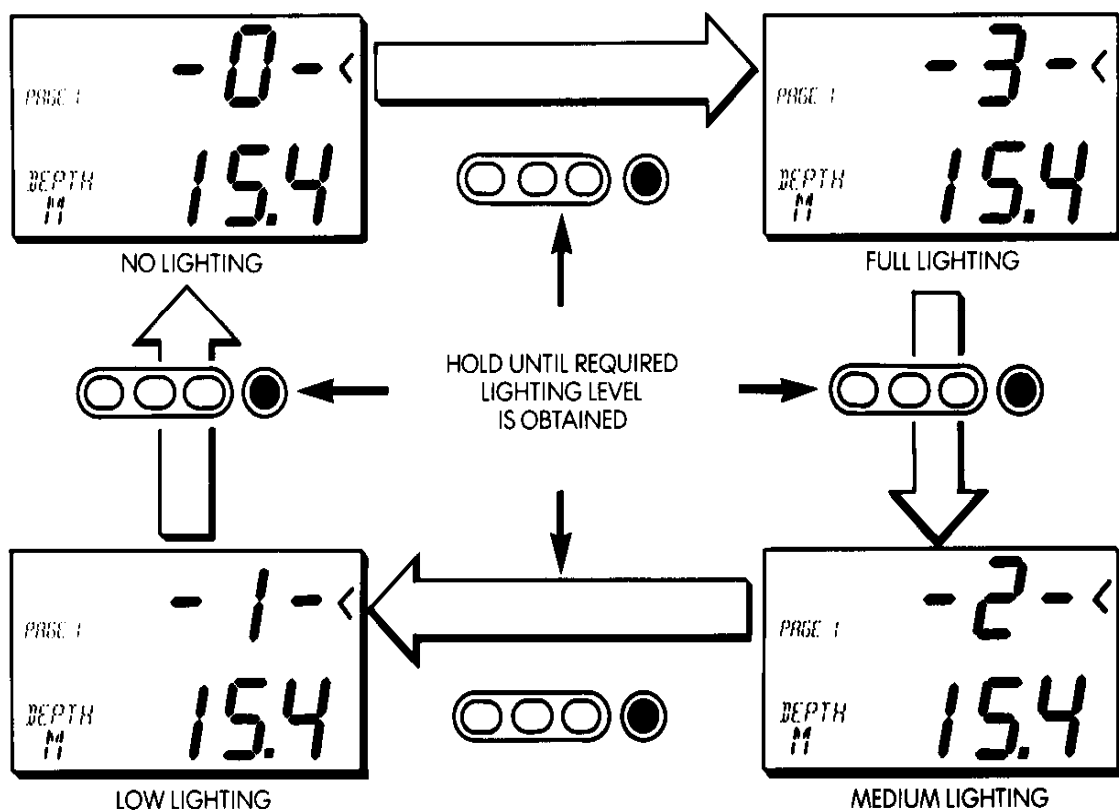

### CALIBRATION

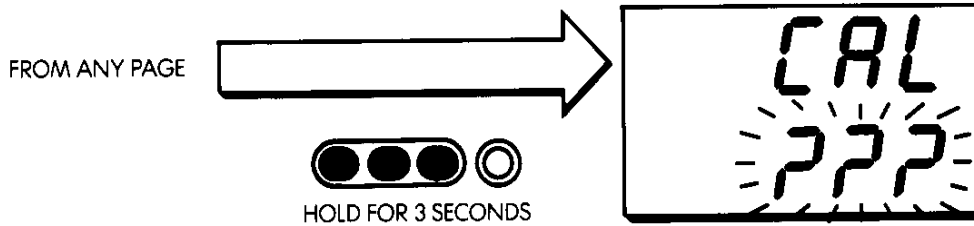

### NOTES ON CALIBRATION

- a) THE CALIBRATION MODE MAY BE EXITED AT ANY POINT BY DEPRESSING THE 3 FUNCTION BUTTONS AT THE SAME TIME.
- b) BY HOLDING DOWN EITHER THE INCREMENT OR DECREMENT KEYS VALUES MAY BE ALTERED RAPIDLY.

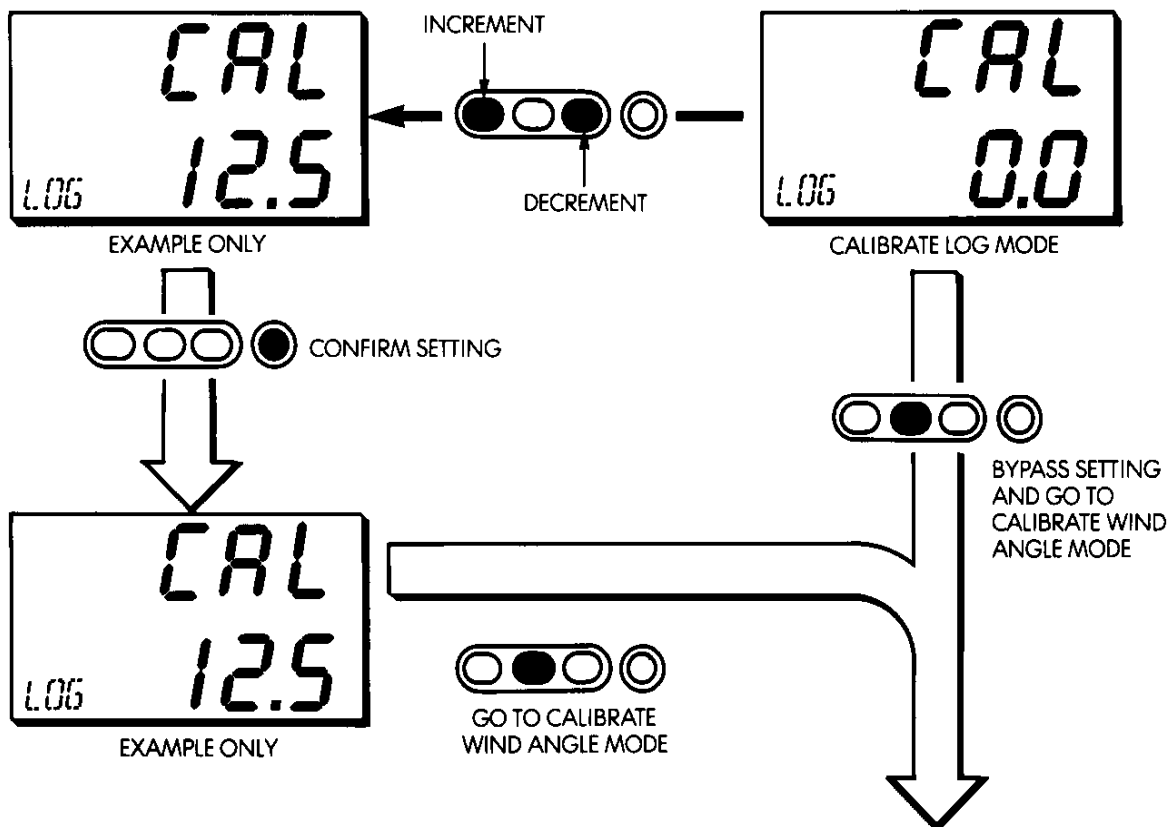
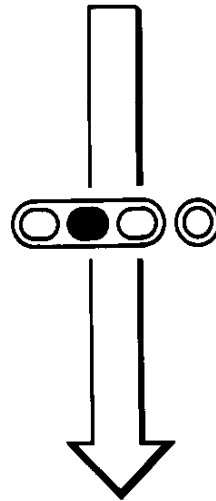

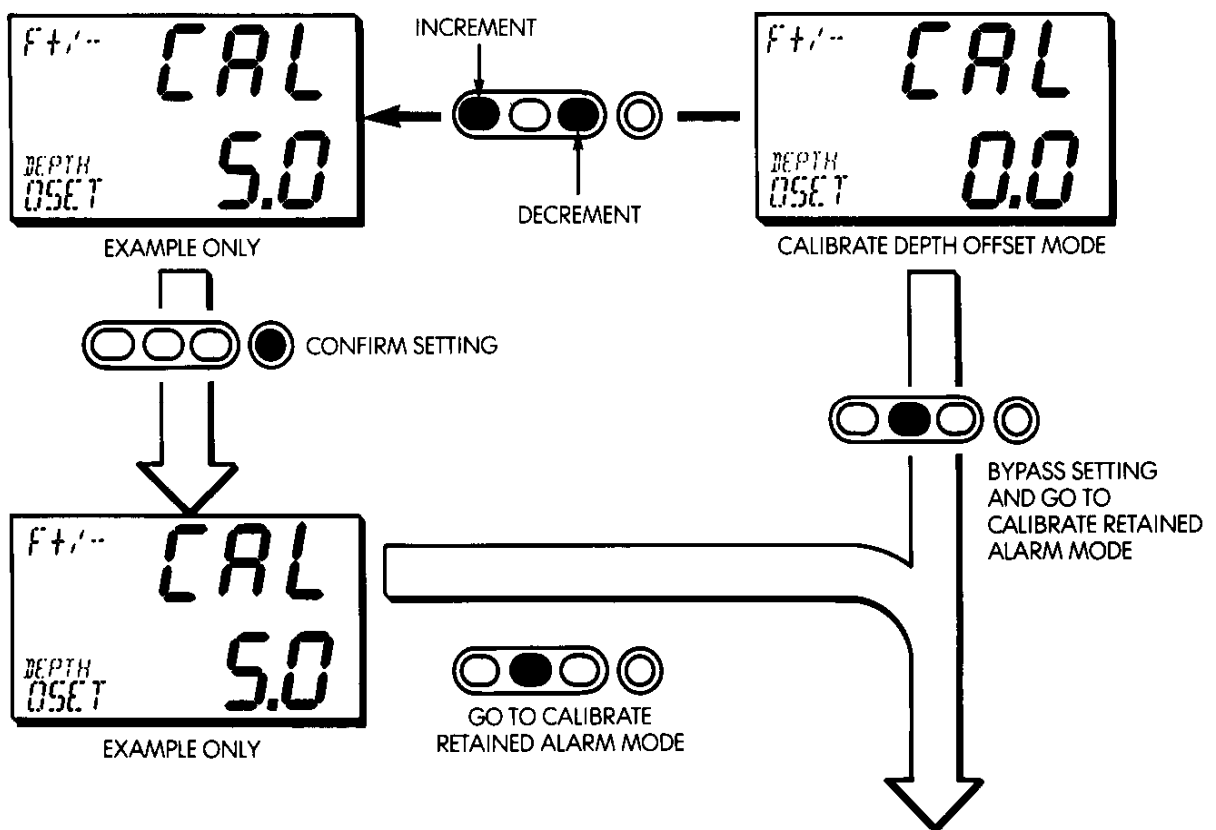
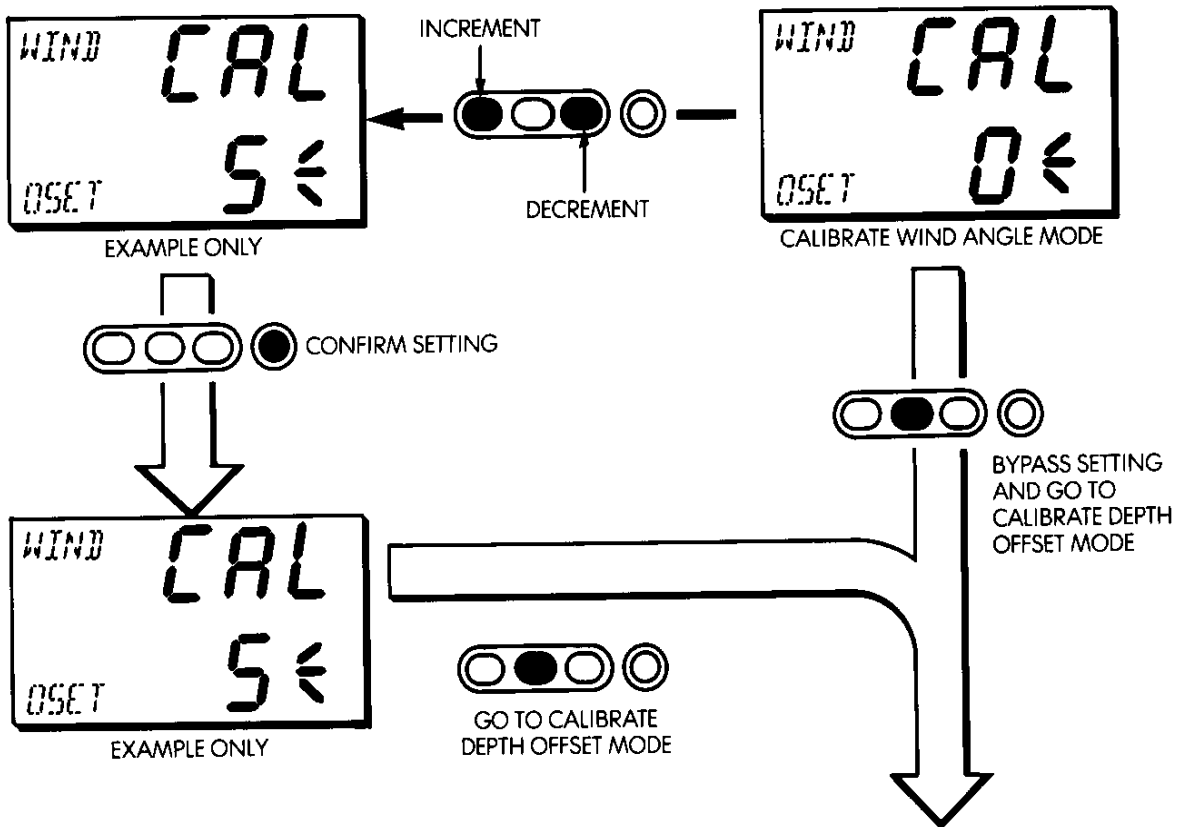

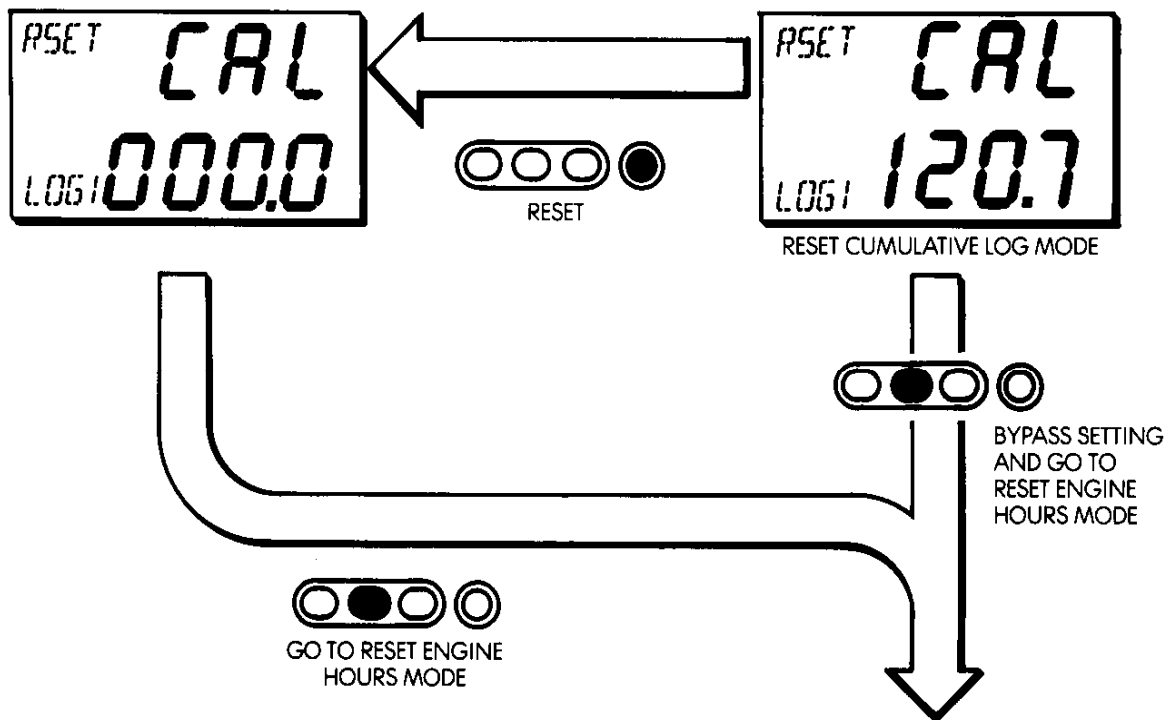
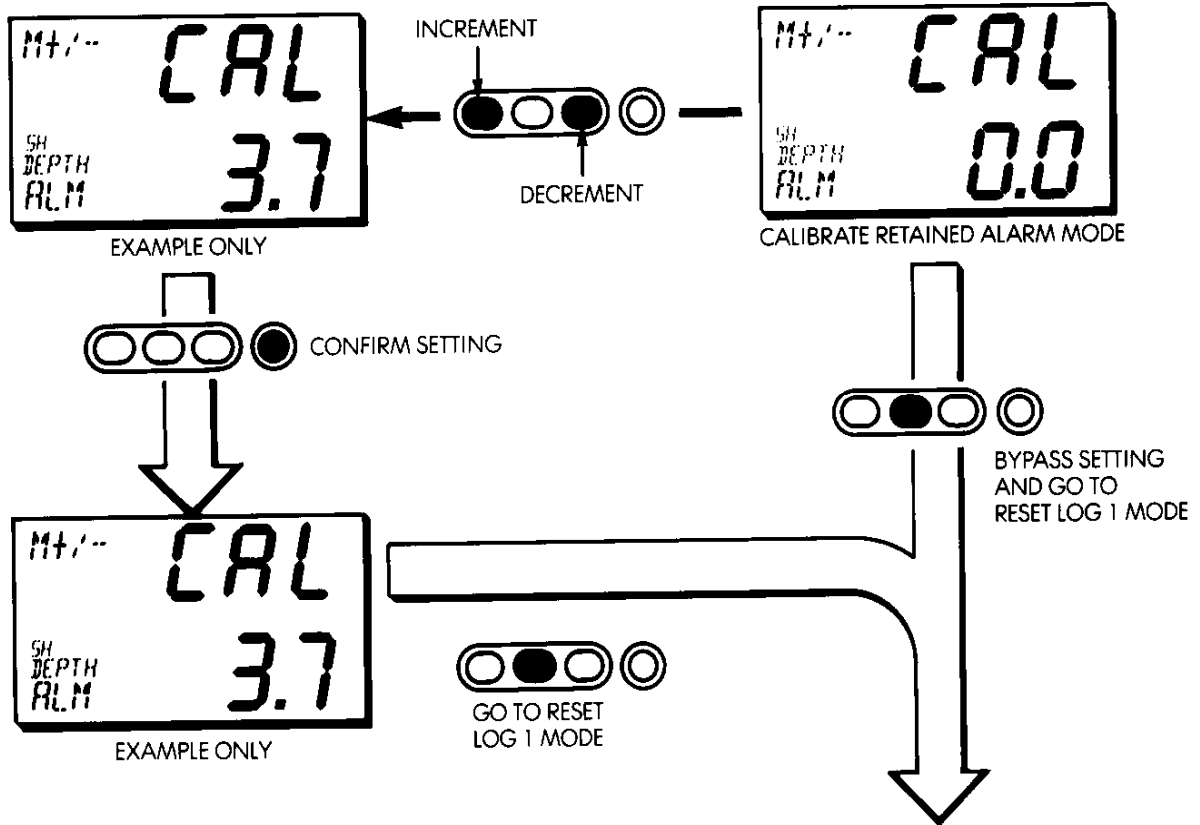



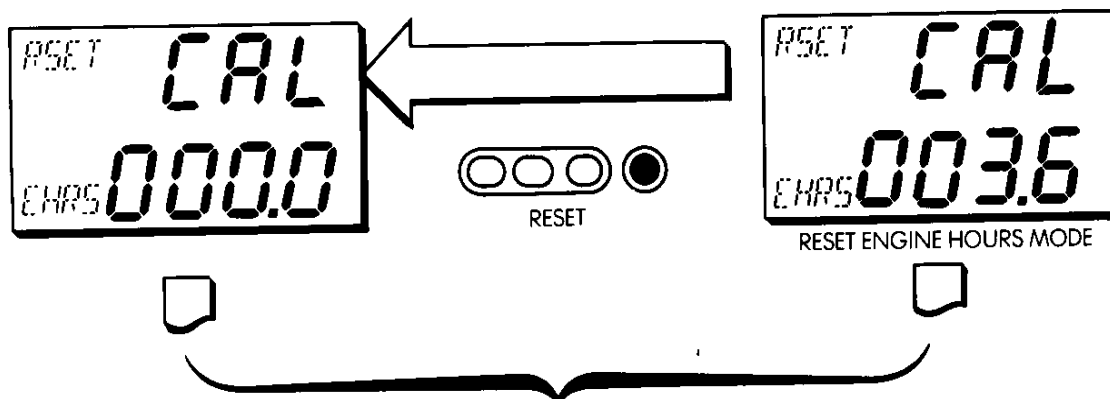

AT THIS POINT THE USER MAY EXIT BACK TO THE ORIGINAL FUNCTION,  
OR MAY REVERT BACK TO CALIBRATE LOG MODE, THUS:

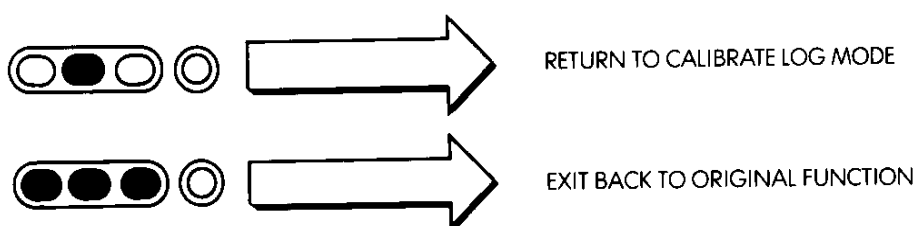

## 6. OPERATIONAL CHECKLIST & TROUBLE SHOOTING GUIDE

Stowe instruments are carefully tested and proven before shipment. However, installation conditions and procedures (and very occasionally failures of components within the instruments) can cause difficulties and the following check list will direct the user to the source and remedy.

For additional assistance call your local agent listed at the rear of the manual.

CONDITION	PROBABLE CAUSE	ACTION
All Repeaters have blank LCD displays	● No 12V power supply	Check Supply Check wiring Check 5A fuse in Databox. Return Databox for service.
All Repeater LCDs show bars	● No information from Databox	Check wiring from Databox to Repeaters, particularly Green and White wires. Return Databox for service.
One Repeater has blank display or bars	● Faulty Repeater	Check wiring at rear of Repeater. Return Repeater for service.
Log, Distance and Boat Speed too low to be brought into calibration	● Dirty paddle or hull ● Hull form produces exceptionally low water speed over paddle	Clean paddle and hull as required.

CONDITION	PROBABLE CAUSE	ACTION
Distance data jumbled after switch on	● Low battery voltage or poor connection	Check battery voltage and connections. Temporarily wire direct to battery if voltage OK but problem persists.

### DEMONSTRATION MODE

This function allows the user to learn the instrument whilst being away from the rest of the system. It allows the user to use all the functions of the instrument, using example values produced by the instrument.

To enter the Demonstration Mode, connect the instrument as follows:

0V to the BLACK terminal

12V to the RED terminal

Before switching on the supply (or connecting to the battery), press the orange 'LIGHT' button, and hold whilst applying power. The instrument will then power up in the DEMO mode.

To leave the DEMO mode, the instrument should be switched off and then back on again in the normal way.

### TRANSDUCERS

Refer to Databox manual for trouble shooting the system transducers.

## 7. CARE AND MAINTENANCE OF INSTRUMENT HEAD

The instrument head will under normal use require little maintenance as the cases are made from high impact material (polycarbonate) to withstand the rigours of an exposed cockpit. It is important to avoid using chemical cleaners and hydrocarbons such as diesel, petrol etc.

If the instrument requires any form of cleaning, use fresh water and a mild soap solution (not a detergent).

It is advisable at the start of each season to check all connections to the instrument head and cover with silicone grease, vaseline or WD40. The dessicant pack at the rear of the instrument above the terminal block should be removed and dried if signs of condensation appear on the instrument glass. This can be achieved by partially removing the M3 screw and pulling on the screw. The pack can then be dried by placing in a warm place for 24 hours. Do not use a gas oven for this purpose.

## 8. REMOVAL OF THE INSTRUMENT

To remove the instrument head, the outer cover must first be removed. This can be done by squeezing the instrument sides between finger and thumb and applying an upward pressure. At the same time place a wide bladed screwdriver between the bulkhead or panel and the cover, and gently rotate. Then remove the four fixing screws securing the head in place, and very gently lever off the head.

